



DATASHEET TAG SEMAFORO PULS. TWEETY – P/N° 7V2475.69



DID YOU KNOW...

The TAG SEMAFORO is the device of the innovative LETismart system, that allows communication between sound traffic lights and the white cane, usually supplied to blind / visually impaired citizens, integrated by the LETismart VOCE system. Bi-directional communication allows the user to receive audio information from the cane about the references of the pedestrian crossing and to INTERACT with the traffic light itself. Specifically, the system allows you to activate the directional sound of the device (LETismart TAG), to be guided to the exact crosswalk's point, and it provides the sound emission of green light WITHOUT looking for the pole and/or the button. It reduces the risks for the users to find themselves in the middle of the congested roadway and it cancels the time to look for the reservation button, avoiding getting dirty. The radio interface sends the encrypted communication on the 868Mhz LoRa band to make the system safe and it uses a dedicated protocol to avoid overlapping between the devices. The electronics is the result of a precise and in-depth engineering study, that has led to a significant miniaturization of the electronic circuit, in order to adapt it to the smallest mechanical boxes on sale, with zero visual impact and minimum size, without affecting its weight.

LAYOUT AND CONNECTIONS OF THE TAG SEMAFORO

SUPPORTED LANGUAGES

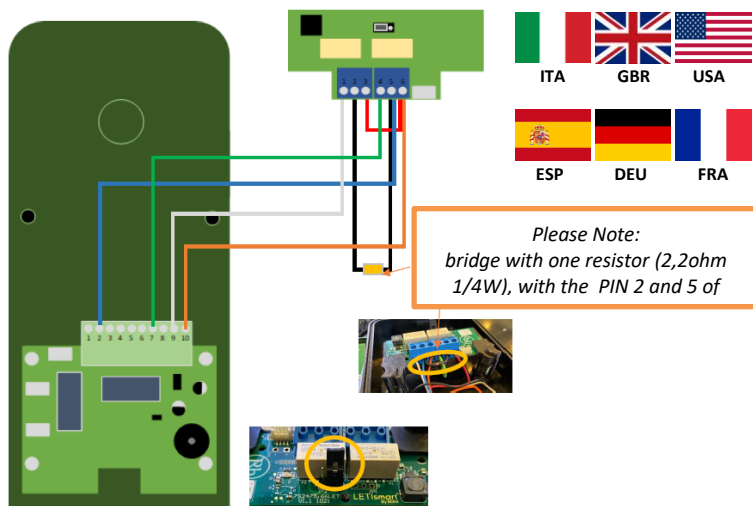

Pin on TAG	Colour	Function	Connect to
1	Grey	Relay1	9 on the button control panel
2	Black	Relay1	5 on TAG with resistor
3	Red	Relay2	6 on the button control panel
4	Green	Relay2	7 on the button control panel
5	Blue	Alim-	2 on the button control panel and 5 on tag with resistor
6	Orange	Alim+	10 on the button control panel

RECOMMENDATIONS

- For a correct use it is required a proper training by a qualified Orientation & Mobility specialist
- Any replacement, updates, installation or maintenance must be carried out by an authorized LETismart service center by SCAE s.p.a.

TECHNICAL FEATURES

Power supply	24Vdc (with peak protection)
Energy consumption (stand-by)	200mW (phrase transmission and waiting for VOCE commands)
Energy consumption (active)	600mW (active sound system)
Radio connection	Wireless LoRa
Transmission band	ISM – 868MHz
Connector	Screw terminal connector
Relays technical features	2A @ 30VDC, 0.3A @ 110VDC, 0.5A @ 125VDC
Pulse timing	Configurable
Adviser activation	
Buzzer volume levels	As SCAE's specifications
Buzzer sound frequency	2kHz
Buzzer timing	ON 1300ms, AT REST 300ms, 1900ms between series
Traffic light reservation sound system	Sound system integrated into the sound traffic light
VOCE must be set in these modes to recognize the TAG	- Urban information - Urban and commercial information
Traffic light mode	- Single traffic light crossing - Traffic lights group
PCBA size and weight	54,2x23,2x14 mm & 12gr

COMPLIANCE

The manufacture is compliant with:

- ETSI EN 300 220-1 V3.1.1 + ETSI EN 300 220-2 V3.1.1 for the radio transmission part (RED).
- ETSI EN 301 489-1 V 1.9.2 + ETSI EN 301 489-3 V 1.6.1 for electromagnetic compatibility.
- Electromagnetic compatibility: 2014/30/EU.
- EN/IEC 62368-1:2014 + AC2015.
- EN 50385:2017
- IPC A 610 G Class III assembly standards, ESD conformity CEI EN 61340 5 1, J STD 001 and J STD 033.
- 2015/863/EU RoHS III (leadfree) Directive.
- Reach 1907/2006/EU_reg453/2010/UE SVHC art31 Registration, Evaluation, Authorization and Restriction of Chemicals.
- Conflict Minerals Policy Statement
- The TAG does not alter the characteristics of the traffic lights panels, which comply with the following standards: CEI 214-7 e 214-7-VI; Legge n. 447 del 26/10/1995; DPCM del 14/11/1997; D.P.R. del 24/07/1996 n. 503 codice della strada; UNI EN 12368/2006